

Hansa C27 HS

Operation, maintenance and safety manual



All operators must fully read and understand this operator's manual before using the chipper.

HANSA NEW ZEALAND

+64 7 849 4749 info@hansaproducts.co.nz

www.hansaproducts.co.nz

HANSA AUSTRALIA

1800 426 722 info@hansaproducts.com.au

www.hansaproducts.com.au

TABLE OF CONTENTS

WHAT CAN MY HANSA CHIPPER PROCESS?	1
INTENDED USES OF THE CHIPPER	1
RECEIVING YOUR HANSA BRUSH CHIPPER.....	1
CHIPPER COMPONENTS	1
SAFETY	2
OPERATOR COMPETENCY.....	ERROR! BOOKMARK NOT DEFINED.
IDENTIFYING HAZARDS AND RISKS	2
TOWING SAFETY	3
OPERATION	3
OUTLET CHUTE ADJUSTMENT.....	3
FEED ROLLER CONTROL	4
AUTOMATIC FEED CONTROLLER (AFC)	4
HOUR METER / TACHOMETER.....	4
CHECKLIST BEFORE OPERATION	4
SAFE SETUP PROCEDURES	5
SAFE OPERATING PROCEDURES	5
STARTING PROCEDURE	7
SHUTDOWN PROCEDURE	8
TROUBLESHOOTING	9
MAINTENANCE & SERVICE	10
KNIFE RE-SHARPENING AND KNIFE REPLACEMENT	10
ANVIL ADJUSTMENT	12
BELT TENSION	13
BELT REPLACEMENT.....	14
HYDRAULIC PUMP BELT ADJUSTMENT.....	15
GREASING BEARINGS & PIVOT POINTS	15
HYDRAULIC SYSTEM.....	16
ENGINE SERVICING	16
OTHER SERVICING	16
ROTOR BEARING REPLACEMENT	16
TYRE PRESSURE	16
MAINTENANCE & SERVICE INTERVALS	17
BOLT TORQUE	18
SPECIFICATIONS	18
DECALS.....	19
HANSA CHIPPER INDUSTRIAL LIMITED WARRANTY	23
EXCLUSIONS.....	23
LIMITATIONS.....	24
CHIPPER WARRANTY PERIOD	24
HONDA ENGINE LIMITED WARRANTY	25
EXCLUSIONS.....	25
LIMITATIONS.....	26
ENGINE WARRANTY PERIOD	26
COMMISSIONING CHECKLIST AND REGISTRATION	27

What can my Hansa chipper process?

Intended uses of the chipper

The C27HS Hansa chipper is built to process organic material including wooden branches not exceeding 160 mm diameter.

Do NOT use the chipper for any other purpose.

Organic wastes include:

- ✔ Prunings, stalks, roots, vegetable matter, hay, grass, bark
- ✔ Branches
- ✔ Palm fronds
- ✔ Dead and hard timbers (Note: these will dull the knives faster)
- ✔ Paper or cardboard

Do NOT process:

- ✘ Flax, root balls
- ✘ Soil, bones, sand, grit, stones, metal



If you have any questions, contact your authorised dealer.



Do NOT exceed 160 mm branch diameter

Receiving your Hansa Brush Chipper

Congratulations on the purchase of a Hansa Model C27HS Brush Chipper.

Chipper components

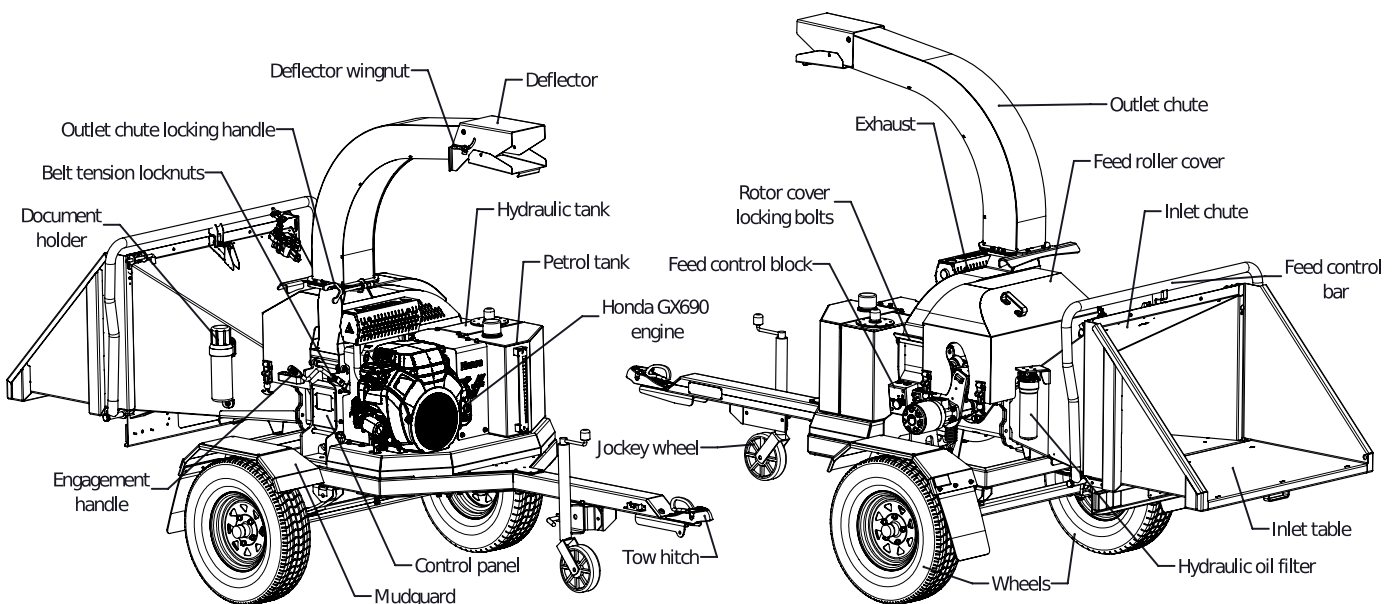

Safety

Preventing accidents is the responsibility of every equipment operator. The operator is responsible for any accidents or hazards occurring to people or their property. Ensure every operator is familiar with the safe operation procedures and controls of the machine, how to identify hazards, and the steps required to avoid injury while handling and operating the chipper. Relevant information is contained in this manual.

- ✘ **Do NOT** modify the design of the chipper.











Operator competency

- ✔ Ensure that every person operating the chipper understands and follows the safe operating and maintenance procedures as detailed in this manual.
- ✘ **Do NOT** allow persons below the age of 16 to operate the chipper. Additionally, local regulations may restrict the age of the operator.
- ✘ **Do NOT** allow persons with reduced physical, sensory or mental capabilities, or lack of experience and knowledge to operate the machine.

Identifying hazards and risks

Identify hazards and risks, and take preventative steps to avoid accidents and minimise risk. Possible hazards include, but are not limited to, moving parts, thrown objects, weight of chipper and components, and the operating environment.

Below is a list of hazards and actions required to prevent injury.

 Hazard	Risk	Corrective action
 Dust	Injury or irritation of the eyes Respiratory irritation	Wear safety glasses Process freshly cut materials and / or wear a dust mask
 Exhaust Fumes	Respiratory irritation	Place the chipper in a manner that the operator or onlookers are not exposed to direct exhaust fumes
 Hot Exhaust	Heat burns	Keep bare hands and other body parts a safe distance away from hot exhaust
 Fire	Heat burns	Clear any build-up of chipping debris around the engine and exhaust regularly
 Belt Drive	Skin pinching and/or abrasions	Ensure that the belt guard is in place, and keep away from the belt
 Cutting rotor and knives	Pinching, crushing, cutting, severing	Keep hands and other body parts out of the inlet chute ✔ Use a stick to push materials into the inlet chute feed roller ✘ Do NOT push material into the feed roller with your hands
 Feed swing arm	Crushing, severing	Do not touch or approach the feed roller motor and swing arm while the machine is operating
 Feed roller and feeding material	Being pulled into chipper resulting in possible crushing, cutting, severing	Do not stand directly in front of the inlet table while feeding material into the chipper; stand to either side. Do not climb onto the inlet table or enter the infeed chute unless the machine is off, and the cutting rotor is stationary.
 Sound	Damage to hearing	Always wear hearing protection when operating the machinery
 Discharge material	Eye injury, minor cuts	Always wear safety glasses when operating the machinery ✘ Do NOT stand in front of the outlet chute ✘ Do NOT face the machinery in a place where the

outlet chute is directed on a hard surface

⚠ Feeding material	Cuts and scrapes	Wear tight fitting safety gloves Wear tight fitting long sleeves and pants to cover bare skin when operating the machinery
⚠ Weight of the chipper	Straining, crushing	Place the machinery on firm level ground ❌ Do NOT attempt to move the machinery up/down slopes unless is attached to a towing vehicle
⚠ Pinch points	Pinching, crushing	When opening/closing the inlet table, rotor cover, or other guard, it is recommended to use the handles provided
⚠ Petrol, oil, grease	Poisoning, skin irritation, harmful vapours	Take care when handling petrol, oil and grease Wash skin if contaminated with petrol, oil or grease ❌ Do NOT refuel the chipper in enclosed areas

Towing safety

- ✔ Rotate the discharge chute to face the opposite direction of the towing vehicle before towing and lock into position
- ✔ Lock the feed table in the up position
- ✔ Connect the tow coupling to the towing vehicle (check the ball dimensions are the same as the coupling)
- ✔ Connect safety chain with shackle
- ✔ If the machine is fitted with brakes, check handbrake is off and road brakes are on by removing the reversing lever
- ✔ Plug in lights and check they are operational
- ✔ Check wheel nuts and axle U-bolts periodically to make sure they are secure
- ✔ Ensure the jockey wheel is in the up position and locked away during transport
- ✔ Ensure the machine is towed in accordance with local trailer transport regulations

Operation

The chipper is self-feeding and has a large inlet opening. It can process:

- Prunings, stalks, vines, leaves, roots and vegetable matter, paper and cardboard
- Freshly cut material is better to process than dry material
- Maximum capacity is 160 mm diameter branches

It is recommended to keep a wooden stick handy, approx. 60 mm diameter x 1000 mm long for:

- Pushing in short, brushy and very leafy materials
- Keeping the inlet table clear



Outlet chute adjustment

The C27HS is fitted with a freely rotating outlet chute, allowing the operator to precisely control the direction of material discharge from the machine. The chute can easily be adjusted by undoing the clamping bolt, adjusting the outlet chute direction as needed, then doing the clamping bolt back up.

Additionally, the end of the outlet chute is fitted with two deflector plates that you can adjust to control the angle and distance that material is discharged. A wingnut is located on the side of the upper deflector to lock it in place.

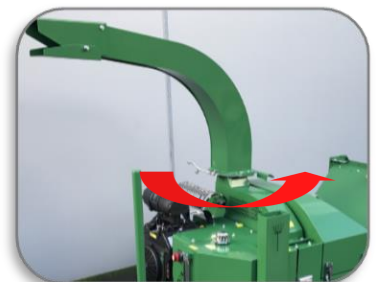

Feed roller control

The C27HS is equipped with a feed roller which facilitates the process of feeding material into the machine. The feed roller is controlled via the yellow control bar which surrounds the inlet table. The control bar has three settings:

- 1) Reverse
- 2) Neutral
- 3) Feed

When the bar is fully pushed in, the feed roller will be set to reverse. When the bar is fully pulled out, the feed roller will feed material. The neutral position lies between the reverse and feed positions.



Automatic Feed Controller (AFC)

The feed roller is fitted with an electronic automatic feed control system which is designed to limit the feed rate of material into the machine in order to prevent the engine from stalling.

This system eliminates the need to control the speed at which the branches are fed into the chipper manually. A sensor detects the RPM of the rotor (and hence the engine). Once the RPM of the rotor drops to a pre-set level the feed roller stops and the branch stops feeding into the machine. The engine then picks up in RPM and once it reaches a pre-set speed the feed-roller will start feeding again. The feed roller will also reverse back slightly after stopping (reducing the friction between the wood and knives) resulting in a quicker engine recovery.

The feed roller will only work once the engine is turned on and the engine has reached full throttle after engaging the rotor. If the green LED light on the AFC controller is flashing this indicates the feed roller isn't turning. When this changes to a solid green light (when the engine reaches maximum RPM) the feed roller will be operational.

The AFC has 19 different pre-set positions at which the feed will stop.

Adjusting the AutoTrip setting:

1. Turn the ignition key into the 'ON' position. Alternatively, this can be adjusted when the machine is in operation.
2. The version number will initially be displayed on the LCD display, wait until this clears.
3. Push the 'Menu' button once.
4. Adjust the AutoTrip setting down using the 'Menu' button or up using the 'Set' button. There are 19 different positions at which the feed will stop. At setting 1 the engine is dropping further in RPM, whereas at setting 19 the engine is only dropping marginally in RPM before the feed roller stops. Adjust to a setting which is most suitable to you. Once adjusted the screen will return to the Hour meter / Tachometer display after 5 seconds, saving the desired setting.

If there are any problems with the electronic automatic feed system, the chipper can be used with the auto-feed disabled. To disable auto-feed, adjust the AutoTrip setting down to 0 or up to 20.



WARNING! Be careful using the machine with auto-feed disabled as the machine can be stalled easily.

Hour meter / tachometer

The LCD display will toggle between the current engine RPM and machine hours every 5 seconds. Alternatively, the operator can toggle between the two by pushing the 'Set' button.

Checklist before operation

Engine:

- ✓ Check oil level in engine
- ✓ Check condition of air cleaner
- ✓ Refer to engine manual for more details

Check Hydraulics:

- ✓ Check level of hydraulic fluid
- ✓ Check all hydraulic components for leaks

General:

- ✓ Check drive belt and pump belt for proper tension
- ✓ Check machine for proper lubrication
- ✓ Check nuts and bolts to ensure they are tight
- ✓ Check tires for proper air pressure as stated on the tire
- ✓ Check petrol level
- ✓ Check that the fuel cap is secured and there is no fuel leaking from the tank
- ✓ Check direction of the discharge chute
- ✓ Check guards are all in place and in good condition
- ✓ Check all labels are legible. Replace if necessary (contact Hansa for replacements)
- ✓ Refer to maintenance section for more details

Safe setup procedures

- ✓ Ensure all pre-operation checks have been done
- ✓ Setup the work site so there is no danger to traffic or public and provide adequate warnings
- ✓ Ensure the chipper is positioned in an open area and on firm level ground.
- ✓ Ensure that chipper components are in place and in good condition
 - ⇒ If any parts are worn or damaged, contact Hansa for replacements
- ✓ Ensure the feed control bar is in the neutral position when starting the chipper
- ✓ Ensure the inlet table is clear of material when starting the chipper
- ✓ Ensure the throttle control lever is initially in the idle position when starting the chipper
- ✓ Ensure the outlet chute is discharged onto soft ground (e.g. grass)
 - ✗ **Do NOT** allow the outlet chute to discharge chip onto hard surfaces (such as a paved or gravel surface)
 - ⇒ Ejected material can rebound and cause injury
- ✓ Keep children, pets and spectators clear of the work area at all times
 - ✗ **Do NOT** operate the chipper where there is a hazard to onlookers
 - ✗ **Do NOT** allow any person under the age of 16 to operate the chipper
- ✓ Refuelling:
 - ⚠ Take extra care in handling fuels
 - ⇒ They are flammable and vapors are explosive
 - ⚠ Use only an approved fuel container
 - ✓ Always replace and securely tighten fuel cap after refuelling
 - ✓ Allow engine to cool down before refuelling
 - ✗ **Do NOT** smoke when using or refuelling the chipper
 - ✗ Never remove fuel cap or add fuel with the engine running
 - ✗ Never refuel the chipper indoors
 - ✗ Never store the chipper or fuel container inside where there is an open flame, such as a water heater
 - ✗ If fuel is spilled, do not attempt to start the engine. Wipe up the spilled fuel and move the chipper away from the area of spillage before starting

Safe operating procedures



DO:

- ✓ **Wear safety equipment:** Safety glasses and earmuffs must be worn at all times
- ✓ **Wear work gloves:** The wearing of work gloves is optional but highly recommended - ensure that the gloves fit tightly
 - ✗ **Do NOT** wear loose fitting gloves or gloves with long cuffs.
 - ⇒ Loose gloves may get snagged by branches, which could result in the operator being pulled into the chipper
- ✓ Tie long hair up
 - ⇒ Long hair could be snagged by a branch and may be pulled into chipper
- ✓ Wear clothes that sit tightly
 - ⇒ Avoid scarves and any items that can get caught in the chipper or snagged on branches
- ✓ Place the chipper on even ground and direct outlet chute onto soft ground
- ✓ Ensure the chipper is positioned so that there is a minimum inlet table height of 600 mm off the ground
- ✓ Ensure exhaust is pointing away from the working area and downwind from the operator and onlookers
- ✓ Keep proper balance and footing at all times and stand at the same level as the chipper
 - ✗ **Do NOT** climb onto the inlet table to push material into the feed roller



- ❌ **Do NOT** run near the chipper
- ✅ Keep your face and body away from the inlet chute. Stand to the side of the inlet table while feeding material into the chipper
 - ⇒ Standing to the side gives better access to the control bar and helps in keeping clear from flying debris
- ✅ Feed only freshly cut material into the chipper
 - ❌ **Do NOT** feed in materials covered in gravel, stones and dirt as this can rebound, injure the operator and damage the machinery
- ✅ Prune to a size that suits the chipper's capabilities
- ✅ Pre-cut side branches
 - ⇒ The branch will 'self-feed' more efficiently
- ✅ Keep the engine clean of debris and other accumulations
 - ⇒ This prevents damage to the engine or possible fire
- ✅ Feed limbs and branches through butt end first, leaving the bushy head on
 - ⇒ This helps guide the limb down the inlet chute
 - ⇒ It reduces spinning and the occurrence of ejection of small pieces back up the inlet chute
- ✅ Feed soft materials intermittently with branches
 - ⇒ The wood chips tend to clean out any soft residue left in the chipper
 - ⇒ The chipper can clog up with soft, wet or fibrous materials
- ✅ Keep well clear of the outlet chute discharge area, even when the chipper is not currently processing material
 - ⇒ High velocity, sharp discharge can cause serious injury
- ✅ Keep the outlet free of blockage
 - ⇒ If blockage occurs, turn the engine off and wait for rotor to stop spinning. Open the outlet chute and remove material until the outlet chute is clear
- ✅ Keep the feed roller free of blockage
 - ⇒ If blockage occurs, turn the engine off and wait for rotor to stop spinning. Remove the feed roller guard by unhooking the four rubber latches. Unhook the springs from the base of the chassis. Lift the swing arm up and insert the rotor pin (located underneath the control panel) into the tab on the housing to lock the swing arm in place (as per the diagram below). You may now safely clear the blockage. Remove the rotor pin, lower the feed roller, reposition the springs, then replace the guard

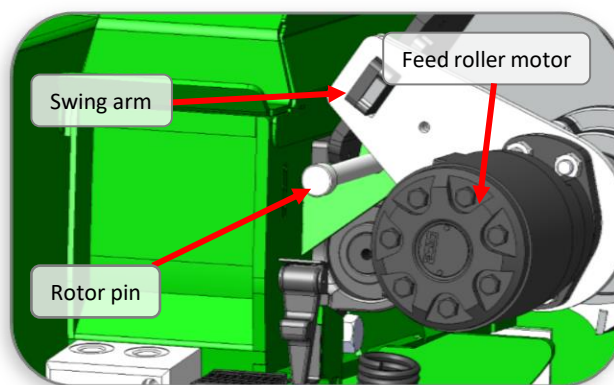

- ✅ Turn off the engine whenever you leave the work area

❌ DO NOT:

- ❌ Run the chipper in an enclosed area
 - ⚠️ Exhaust fumes contain carbon monoxide which is poisonous, colourless, odourless, and tasteless
- ❌ Operate the chipper wearing loose clothing and untied long hair
- ❌ Stand at a higher level than the base of the chipper when feeding material into it
- ❌ Feed flax and cabbage tree leaves into the machine
 - ⇒ These stringy materials can wrap around the rotor shaft and work their way into the bearing.
 - ✅ If any stringy material becomes wrapped around the rotor shaft, remove it before it works itself into the bearing
- ❌ Process old materials such as dried wooden branches
 - ⇒ They get very hard and springy when dried out
 - ⇒ They are more awkward to handle
 - ⇒ The knives dull much quicker
- ❌ Feed short, stubby pieces of wood into the chipper

- ⇒ They bounce and spin in the inlet chute
- ✔ Feed short stubby pieces together with longer pieces
- ✘ Feed branches that are too large (max 160 mm branch diameter)
 - ⇒ The chipper engine will stall, which could result in damage to the engine or drive belts
- ✘ Put soil, sand, grit, stones, glass, pieces of metal or other foreign objects into the chipper
 - ⇒ This will damage the sharp edge of the cutting knives and can rebound and injure the operator
- ✘ Put root balls and dead wood into the chipper
 - ⇒ This dulls the knives quickly
- ✘ Overload the chipper
 - ⇒ If the cutting rotor is slowing down, feed the material in slower
- ✘ Transport the chipper while the engine is running
- ✘ Tamper with the engine governor settings on the chipper
 - ⇒ The governor controls the maximum safe operating speed and protects the engine and all moving parts from damage caused by overspeed
- ✘ Operate the chipper with blunt knives
 - ⇒ This causes excessive vibration which may result in damage to the chipper
- ✘ Remove any guards on the chipper unless the engine is turned off and the cutting rotor has come to a complete standstill
- ✘ Enter the inlet chute
- ✘ Get on, or lean over the feed table
- ✘ Put hands or any other part of the body or clothing:
 - ⇒ Inside the inlet chute
 - ⇒ Inside or near the opening of the discharge chute
 - ⇒ Near any moving part
- ✘ Use the feed control bar as a handle to manoeuvre the machine

Starting procedure

Before proceeding, ensure the 'safe setup procedure' has been followed on page 5 of this manual.

1



Ensure the rotor is disengaged by winding the engagement handle in the counter clock-wise direction until the handle comes to a stop (located next to the control panel).

2



Throttle lever (1/2 position)

Choke knob ("on" position)

Ignition key ("on" position)

Move the engine throttle control to approximately half throttle. If the engine is cold, pull the choke knob out to the "on" position.

Insert the key and turn it clockwise to the "on" position. Turn it further clockwise to operate the starter, and hold until the engine has started. Allow the engine to warm up for 1-2 minutes.

⚠ WARNING: Never run the starter motor for more than 5 seconds at a time. Allow to cool for 1 minute before attempting another start.

3

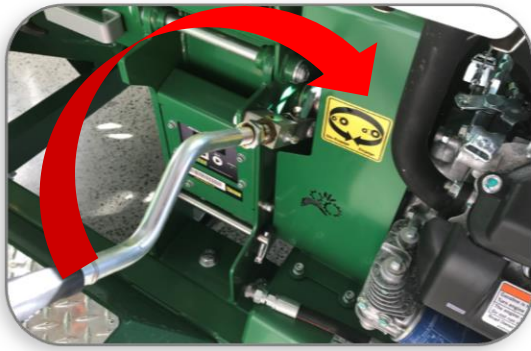

If the choke knob was pulled out to the “on” position, gradually push it in to its “off” position. Gradually and slowly engage the rotor by winding the engagement handle in the clock-wise direction until it comes to a stop. This should be done slowly to allow enough time for the cutting rotor to pick up speed without stalling the engine.

4

Increase throttle to full for chipping (move the throttle lever to the top-most position).

Note: The engine must run at full throttle for the automatic feed control and feed roller to operate. Refer to the ‘Automatic Feed Control’ section on page 4 to set the automatic feed control to the desired setting.

Shutdown procedure

1



To shut the machine down, move the throttle control lever to the “min” position.

2



Once the engine has been given enough time to slow down to idle speed (about 10-15 seconds), disengage the rotor by winding the engagement handle in the counter clock-wise direction until the handle comes to a stop.

! WARNING! Only engage and disengage the rotor at idle speed otherwise excessive vibration and belt friction may cause damage.

3



Allow the engine to cool down by running at idle for at least 1 – 2 minutes before shutting down. Turn the ignition key anti-clockwise into the off position to shut the chipper down.

! WARNING! The heavy rotor will continue to turn for some time after the engine has been shut down. Do not open the rotor housing cover until the engine and cutting disk have completely stopped and the rotor is disengaged.

Troubleshooting

- ❓ The chipper won't start
 - The engine oil level might be too low
 - ⇒ The chipper is fitted with oil alert and will not start if the oil level is too low
 - ✔ Check the oil level and top up if required
 - The chipper is placed on a slope
 - ⇒ The chipper is fitted with oil alert and will not start if the oil is not level
 - ✔ Move the chipper to level ground
- ❓ Belt drive engagement will not work
 - The housing might be blocked
 - ✔ Turn engine off, disconnect the spark plug wire, ensure rotor has completely stopped, remove debris, restart engine, then attempt to re-engage the belt drive
- ❓ Drive belts squealing/smoking
 - Drive belts are loose/damaged
 - ✔ Turn the engine off, disconnect the spark plug wire, ensure rotor has completely stopped. Follow the belt tensioning procedure on page 13
- ❓ Discharge slows down
 - The chipper is clogged up
 - ✔ Turn the engine off, disconnect the spark plug wire, ensure rotor has completely stopped, remove debris, then close and lock the outlet chute
- ❓ Outlet chute is blocked
 - ⇒ Outlet is pasted with wet/leafy material
 - ✔ Feed hard, dry material in with softer material
 - ✔ Turn the engine off, disconnect the spark plug wire and ensure rotor has completely stopped. Open up the outlet chute and clear blockage
- ❓ The material is ejected in long strips
 - The knives and/or anvil might be blunt
 - ✔ Turn the engine off, disconnect the spark plug wire and ensure rotor has completely stopped. Inspect and sharpen or replace knives and/or anvil as required. Ensure correct clearances between knives and anvil
- ❓ The chipper starts making unusual noise, the cutting rotor strikes a foreign object or the chipper starts to vibrate
 - ✔ Turn the engine off, disconnect the spark plug wire, ensure rotor has completely stopped, then inspect for damage
 - ✔ Replace or repair any damaged parts
 - ✔ Check for and tighten any loose parts
 - ✖ **Do NOT** attempt to repair the chipper unless you are competent to do so
- ❓ The chipper stalls when material is being fed
 - ⇒ Auto Feed Control is not working
 - ✔ Check that AFC is on
 - ✔ Check the Autotrip setting is not at setting 0 or 20 (manual mode)
 - ✔ If AFC is not working, contact Hansa
- ❓ The feed roller is not turning
 - ⇒ Engine is not running at full throttle
 - ✔ Increase the engine throttle to max RPM
- ❓ The feed roller is running too slow
 - ⇒ Hydraulic pump belt loose/broken
 - ✔ Tension/replace belt



WARNING! Do NOT open the housing unless the engine and cutting rotor have completely stopped.

Maintenance & service

Knife re-sharpening and knife replacement

How do I know that the knives need re-sharpening?

- ⇒ Chipper is vibrating excessively when processing material
- ⇒ Chipper is making more noise than usual when processing material
- ⇒ Rotor RPM is dropping more quickly than usual
- ⇒ Material comes out in long strips



WARNING! Do NOT operate your chipper with blunt knives.

- ⇒ Blunt knives will cause excessive vibration
- ⇒ Blunt knives result in damage to the chipper

How to re-sharpen the knives:

If you don't have a surface grinder or are unsure how to re-sharpen the knives, contact a professional saw doctor or Hansa to arrange re-sharpening.



WARNING! Be careful when working around the sharp knives.

Tools and materials required for re-sharpening (approx. 40 mins):

- 24 mm ring spanner
- 16 mm ring spanner
- 8 mm Allen key
- Torque wrench with 18 mm and 24 mm socket
- A stick magnet (optional)
- Surface grinder
- Coolant

Remove the knives for sharpening:

1

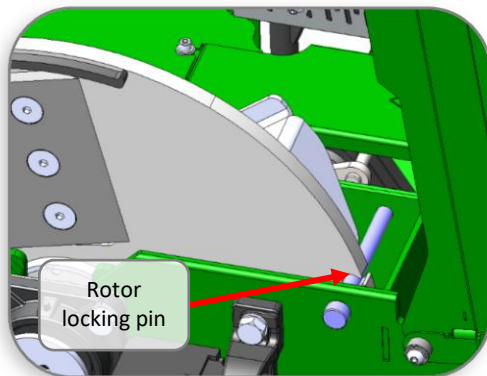

Open the rotor housing cover by removing the two housing cover locking bolts with a 16 mm spanner, then lift the rotor housing cover to access the cutting rotor. Rotate the cutting rotor to gain access to the knives, then insert the rotor pin (normally located under the control panel) into the housing and through the cut-out in the rotor to lock it in place.

2

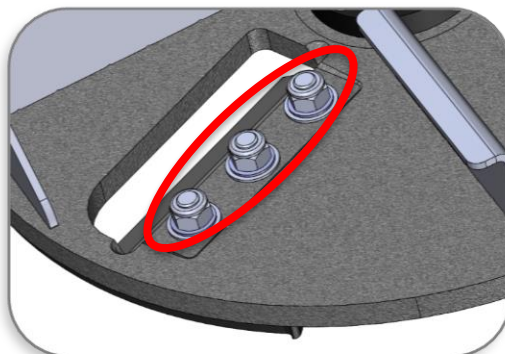

Using a 24 mm spanner and an 8 mm Allen key, remove the knives from the rotor. There are three bolts that you must remove on each knife to do so.

- ⇒ Be careful not to drop the bolts or knives into the chipper.
- ⇒ A stick magnet can be used to retrieve them if this does occur.

3

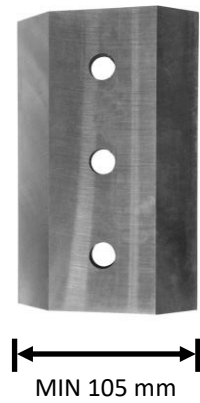

Measure the width of the knife and check that it will be at least 105 mm after sharpening.

If the knives will be shorter than 105 mm, then the knives should be replaced. Please contact your nearest Hansa dealer.

Sharpen the knives:

4



Sharpen the knives on a surface grinder. A cutting angle of 31° is critical for the performance of the chipper. Make sure there is plenty of coolant used when grinding to avoid softening of the steel knives.

Note: You do not need to sharpen your knives unless both sides of the reversible knives have been used.

Reinstall the knives:

5

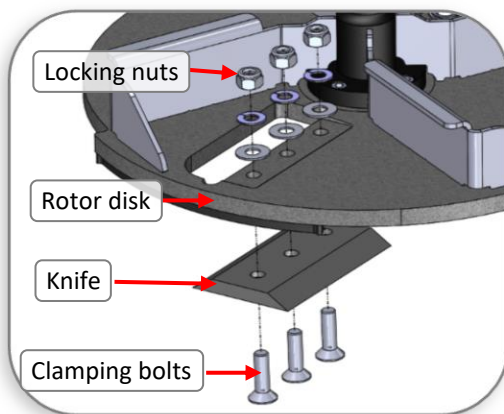

Side view: Cutting rotor

Clean all mounting surfaces and remount the knives in the reverse procedure. Torque the knife clamping nuts up to 190 Nm.

6

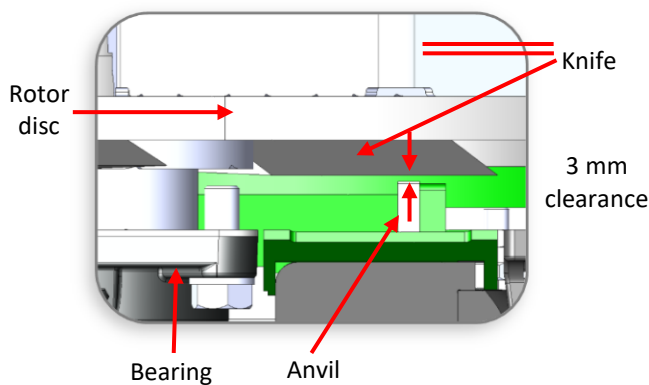

Top view: Knife and anvil set-up

After sharpening, the width of the knives will have been reduced, therefore the gap between the knives and anvil may require adjustment. There should be 3 mm of clearance between the knife and the anvil. If there is not enough clearance, the knife edge may touch the anvil through deflection when cutting heavy branches and damage the sharp edge. Too much clearance will allow small twigs and fibrous materials to be dragged through without being cut.

To adjust the gap between the knives and the anvil, first loosen the locking nuts from the adjustment bolts on the anvil mounting plate using a 16 mm spanner. Now tighten or loosen the two adjustment bolts. Tightening these bolts will cause the anvil mounting plate to slide further along the slotted

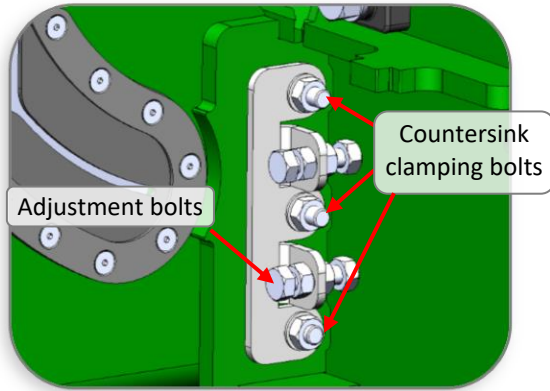

holes. Ensure you tighten the two bolts evenly to avoid setting the anvil on an angle.

Once the correct anvil position has been set, ensure the locking nuts on the adjustment bolts are tightened. Additionally, ensure the clamping nuts are torqued to 44 Nm.

Remove the rotor pin and turn the rotor slowly by hand to check that it turns freely.

7

Close and secure the outlet chute.



WARNING! Every time the knife clamping bolts are torqued up to 190 Nm and loosened off again, the life of the bolts is reduced. The knife clamping bolts must be replaced at most after every six sharpens. Contact Hansa for replacement bolts (m16x50 countersunk bolts of grade 12.9 or higher). Use only genuine Hansa bolts.

Anvil adjustment

Whenever the chipper knives are inspected/sharpened, the condition of the anvil should also be checked. If the edge of the anvil is significantly rounded and/or uneven, then it should be reversed or replaced. Typically the anvil will maintain its sharp edge for about 500 hours of operation.

Anvil replacement

1

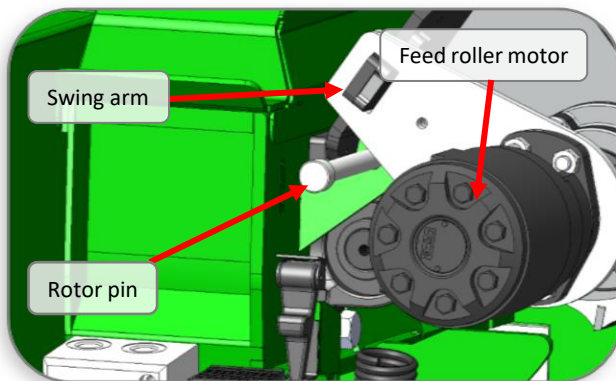

Remove the feed roller cover by unhooking the four rubber latches. Unhook the springs from the base of the chassis. Lift the swing arm up and insert the rotor pin (located underneath the control panel) into the tab on the housing to lock the swing arm in place.

2

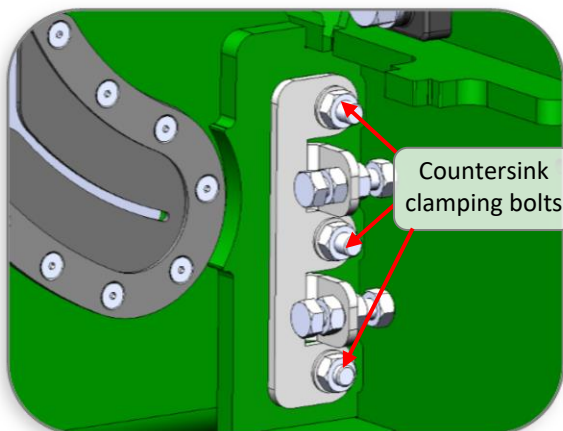

To remove the anvil, you must remove the three countersink clamping bolts using a 16 mm socket and extension. If the bolt head turns, hold it with a 6 mm Allen key.

Note: Do NOT use the Allen key to turn the bolt; turn only the nut.

Note: Ensure the gap between the edge of the knives and the edge of the anvil is 3 mm. If not, then the anvil can be adjusted via the two adjustment bolts between the clamping bolts (as per step 6 of page 11).

3

If the other side of the anvil hasn't been used yet: rotate the anvil 180 degrees and place it back on the feed roller housing wall. If both sides of the anvil are blunt: remove the anvil and replace it with a new one. Contact Hansa if a replacement anvil is required.

4

Tighten the clamping bolts back up using a 16 mm spanner/socket, ensuring there is a spring washer between the clamping plate and each nut. Torque the nuts to 44 Nm.

Belt tension

Correct belt tension is crucial for minimising belt wear and maximising machine efficiency. To check the belt tension, fully engage the belt then open the bonnet. There should be approximately 5 mm deflection in the belt when pressing firmly on the belt (as per the image below). If required, adjust belt tension.

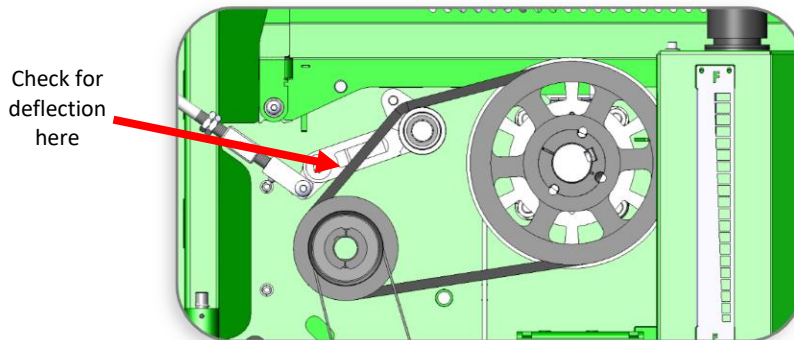

Belt tension adjustment

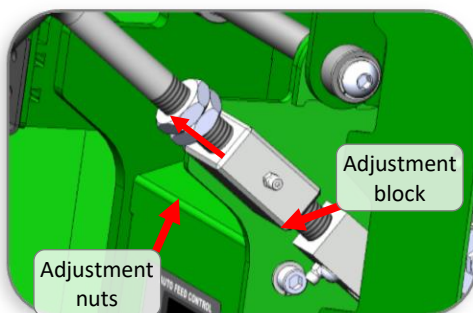
1

Using two 24 mm spanners, unlock the two locking nuts from above the adjustment block on the engagement handle by turning the top nut anti clockwise and the bottom nut clockwise. Then move both locking nuts upward along the thread.

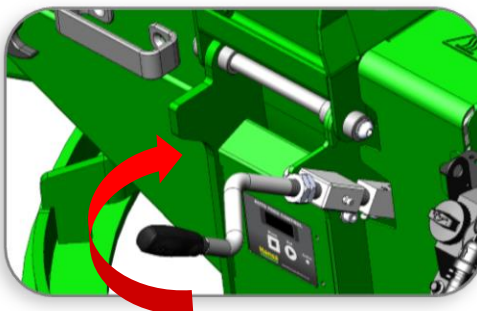
2

From the fully disengaged position, gently turn the engagement handle clockwise until you feel it start to resist. From this position, turn the engagement handle two full revolutions in the clockwise direction, or until there is a significant resisting force on the handle (there should be about 5 mm deflection when pressing firmly on the belt). This is the recommended tension for the belt drive when in the fully engaged position.

Note: For new belts, allow another half revolution as the tension will need to be increased after belt wear.

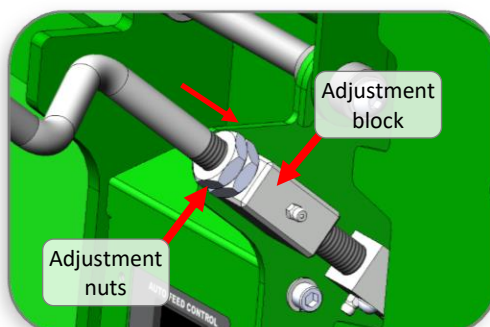
3

Using two 24 mm spanners, screw the two M16 adjustment nuts downwards until they touch the adjustment block. Then turn the top nut clockwise and the bottom nut anti clockwise simultaneously to lock the nuts in place.

The new belts will wear into the pulley. Recheck the belt tension after 10 hours of machine operation, and if necessary, adjust them to the correct tension by repeating this process.

Belt replacement

If the belts in your chipper look similar to any of the following images or are clearly broken, then they need to be replaced.

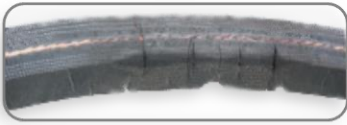

Cracked underside of belt



Split belt cover



Soft, swollen belt



Worn cover on back of belt



Sidewall belt wear

If a belt change is necessary, follow these steps

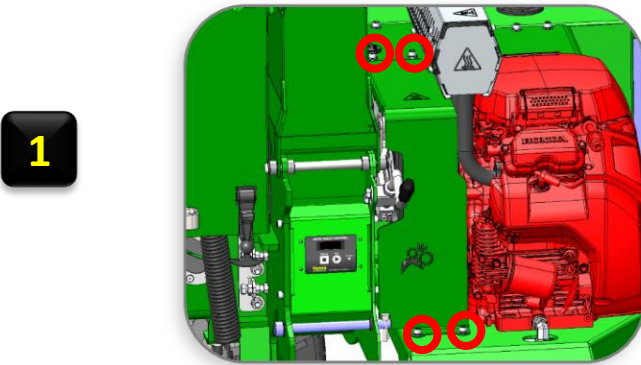

1

Using a 5 mm Allen key, unbolt and remove the pulley guard (4 x M8 cap screws).

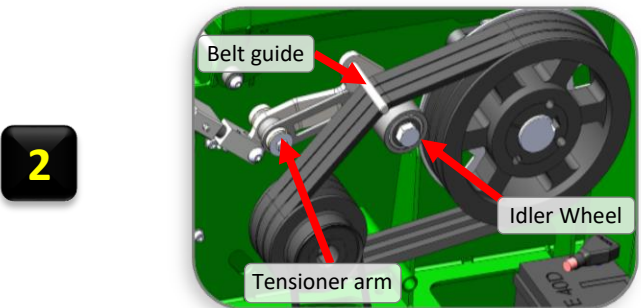

2

Turn the engagement handle counter clockwise until the belt is fully disengaged. Remove old belts and replace (3 x B46 vee belts).

Note: The belts pass in between the idler wheel and belt guide on the tensioner arm.

Note: Engine not shown in this view.

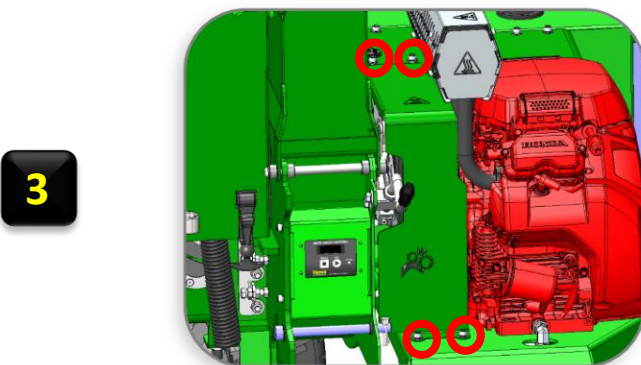

3

Ensure belts are properly tensioned (follow the 'Adjusting belt tension' process on page 13) before fastening the pulley guard back into place.

Hydraulic pump belt adjustment

The hydraulic pump is driven by a synchronous belt. The belt does not require any tension, however the belt should not have any slack either. The belt can be adjusted by loosening the four mounting bolts (using a 13 mm spanner) and moving the pump/pulley up or down the slotted holes (as per the image below). The lower two bolts are best accessed from beneath the machine. If the belt is damaged in any way, contact Hansa for a replacement.

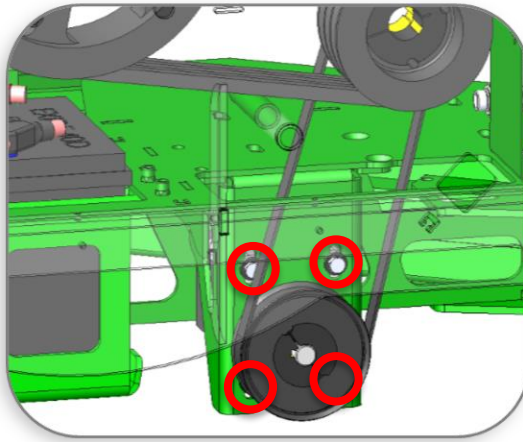

Greasing bearings & pivot points

Points that need to be greased are as follows (as per the diagram below):

1. Two bearings on the rotor shaft, one under the engine cover and the other above the inlet opening
2. Two bearings on the feed roller
3. Two bearings on either side of the feed roller pivot
4. Outlet chute swivel, two grease nipples
5. One grease nipple on the engine engagement screw

These points must be greased every 50 operating hours. Ensure a suitable grease is used (bearing grease or all-purpose grease).

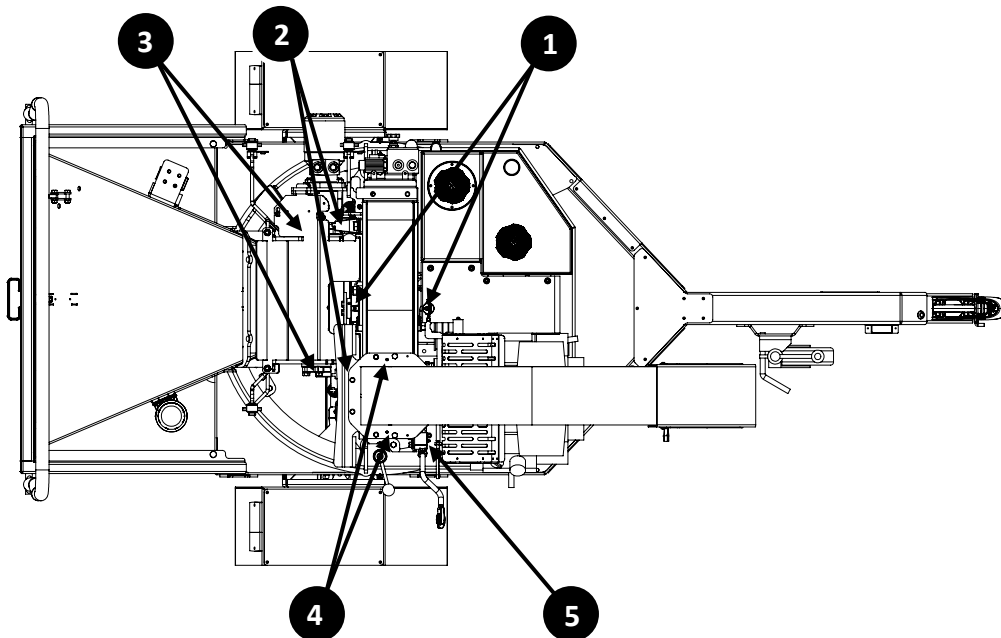

Hydraulic system

Replace oil filter after first 50 hours, then every 250 hours.

The hydraulic oil should be changed every 800 hours. It is a closed system therefore it should not become contaminated, however if contamination is detected oil should be changed. Use only a good quality brand, 32 grade hydraulic oil.

Fill the hydraulic oil tank up to the black indicator mark to the left of the hydraulic oil level indicator. The level should be checked with the engine off.

For any repair in the hydraulic system, contact Hansa Products or seek advice from a competent service agent.



Engine servicing

For servicing of the engine, please refer to the engine manual. Change oil, oil filter, fuel filter and air filter as recommended in the manual. Ensure the correct engine oil is used.

Other servicing

- ✓ Check all bolts and other fasteners for the correct torque setting
- ✓ Check wheel nuts and U-bolts are fastened correctly
- ✓ Check and repack wheel bearings with grease every 12 months
- ✓ Check air pressure in tires. Inflate to pressure as indicated on the tire
- ✓ Check safety chains and hitch

Rotor bearing replacement

Replacing rotor bearing on engine side of rotor:

1. Remove engine pulley by unbolting both grub screws in bush. Then screw one grub screw into the third hole and tighten until the pulley separates from the bush. Slide bush off the shaft, followed by the pulley.
2. Remove two grub screws in the bearing.
3. Remove M16 nuts and bolts bolting the bearing to the housing.
4. Remove and replace bearing.
5. When replacing the pulley ensure the rotor pulley is lined up to the engine pulley with a straight edge. Ensure the grub screws are tightened evenly so the pulley is tightened evenly.
6. The gap between the end of the sensor and the sensing plate should be approximately 3 mm. Adjust the sensor accordingly. If it is set further away, then the sensor may not work properly and therefore the AFC will not work.

Replacing rotor bearing on inlet chute side of rotor:

It is recommended to have this bearing replaced by a specialist Hansa dealer.

Tyre Pressure

The recommended tyre pressure is 65 Psi.

Maintenance & service intervals

Service	Maintenance interval - service hours							
	10 or Daily	50 or Weekly	100	250	500 or Biannually	800	Yearly	As req.
Engine oil change - initial change	Initial							
Hydraulic oil filter - initial replacement	Initial							
Belt tension – check	Initial							
Engine oil level – check	•							
Coolant level - check	•							
Radiator screen – check/clean	•							
Air cleaner element – clean	•							•
Bearings – grease		•						
Engine engagement rod – grease		•						
Outlet swivel – grease		•						
Knives– check, sharpen or replace		•						•
Belt guarding – remove and clean chip build-up		•						•
Drive belts tension - check/adjust			•					
Hydraulic pump belt tension - check/adjust			•					
Fan belt – check			•					
Engine oil & filter – change			•					
Nuts & bolts – check torque			•					
Tires & rims – check			•					
Hydraulic system – check			•					
Spring mounting – check U bolts			•					
Brake fluid - check			•					
Hydraulic oil filter - replace				•				
Battery electrolyte level & terminals - check				•				
Engine fuel filter – replace				•				
Outlet chute – remove & clean swivel				•				
Feed roller tension springs - replace				•				•
Anvil - Check				•				•
Air cleaner element – replace					•			
Hydraulic oil & filter – replace						•		
Feed roller teeth – sharpen							•	•
Engine system								•
Battery – replace								•
Drive belts – replace								•
Hydraulic pump belt – replace								•
Knives – replace								•
Anvil – replace								•
Hazard labels – replace								•

Bolt torque





When servicing the machine, ensure any bolts you remove are torque to the values listed in the torque table below:

		Relative Strength Bolt Marking			
		4.6		8.8	
Bolt size	Spanner size	Recommended Tightening Torque		Recommended Tightening Torque	
		lb ft	Nm	lb ft	Nm
M8	13 mm	6	8.5	16	22
M10	16 mm	12.5	17	32	44
M12	18 mm	22	30	57	77
M16	24 mm	54	73	140	190
M20	30 mm	105	143	274	372

Specifications

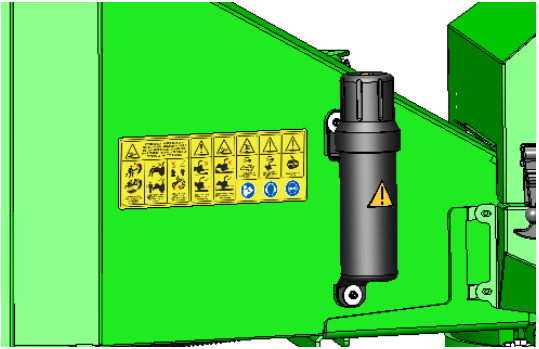
		C27 HS
General	Length	3150 mm
	Width	1585 mm
	Height	2155 mm
	Weight	750
Engine	Make & model	22.3 HP Honda GX690
	Type of fuel	Petrol
Capacities	Fuel tank	33 L
	Hydraulic oil tank	23 L
Chassis	Frame description	75 x 50 x 3 mm RHS
	Wheels	13" wheels
Cutting System	Disc speed	1800 RPM
	Disc diameter	650 x 20 mm
	Shaft diameter	50 mm
	Knives	Two, reversible
Feed System	Feed opening	330 x 178 mm (13" x 7")
	Chipping capacity	160 mm (6.5")
	Feed table height	700 mm
	Feed table length	1550 mm
	Inlet chute opening	960 x 650 mm
	Roller Style	Single roller, spring mounted, 300 mm (12") diameter
	Feed speed range	0-40 m/min (135 f/min), full reverse
Discharge System	Discharge height	2155 mm
	Degree of rotation	360°
Transmission System	Belt drive	3x B46

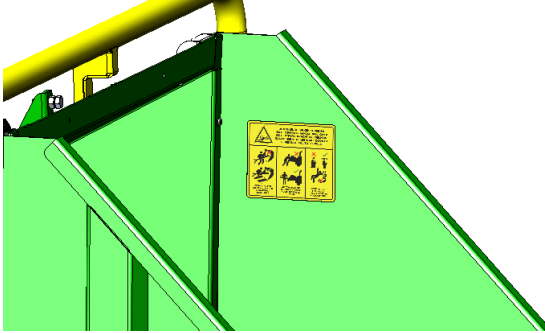
Decals

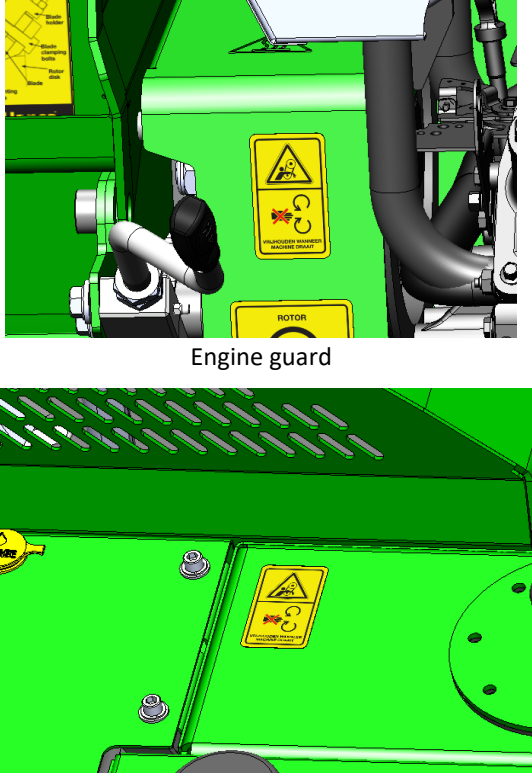
Decal	Description	Location
	<p>General machine safety and inlet chute safety</p>	 <p>Side of inlet chute</p>
	<p>Inlet chute safety</p>	 <p>Inside of inlet table</p>
	<p>Belt hazard</p>	 <p>Engine guard</p> <p>Left side of hydraulic tank</p>

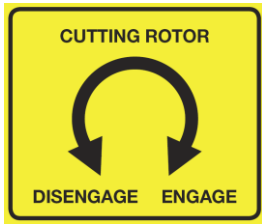

Rotor engagement control

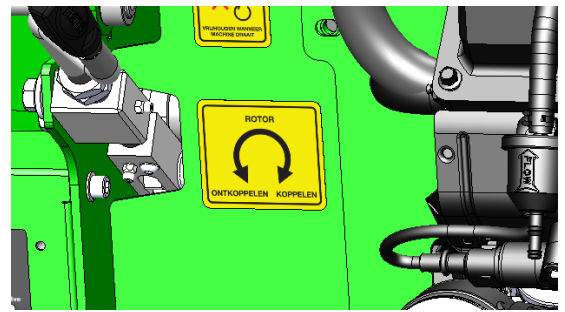

Belt guard next to engagement arm

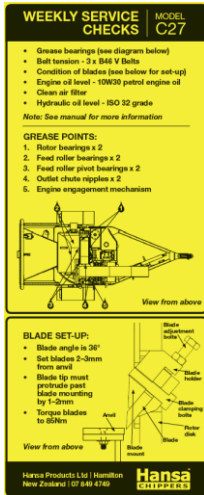

Weekly service checks

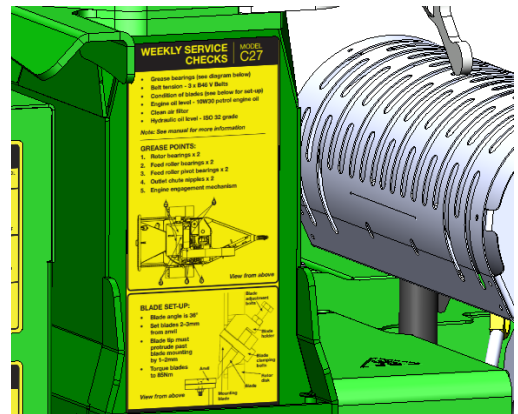

Rotor cover back



Stop procedure

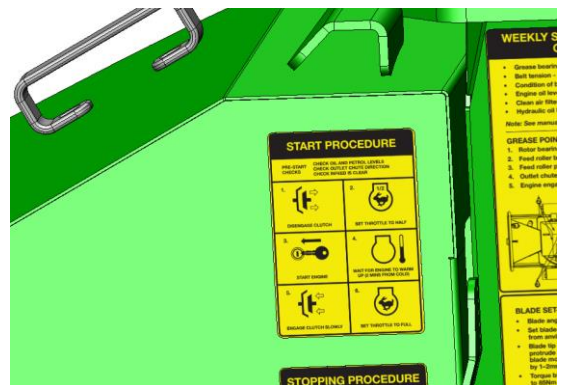

Feed roller cover

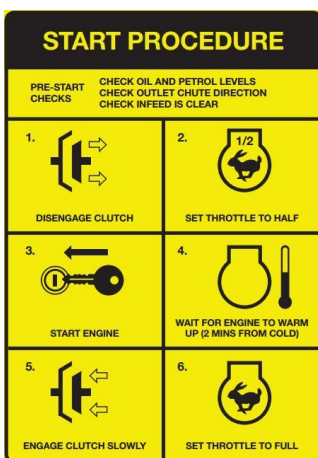

Start procedure

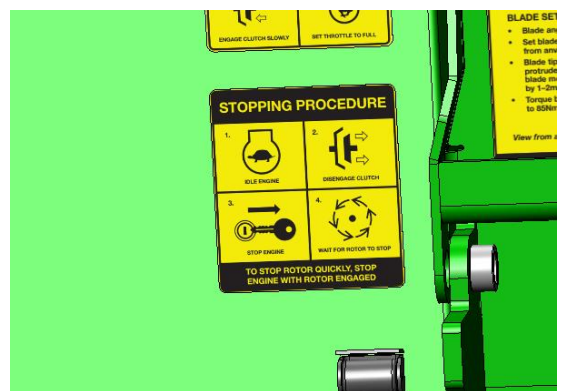

Feed roller cover



Outlet chute safety



Outlet chute

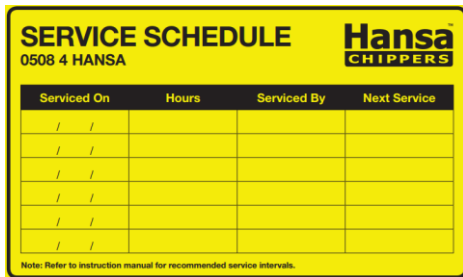

Service schedule

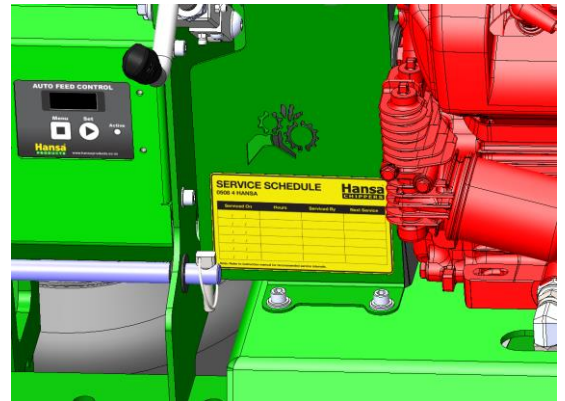

Chassis base



Petrol tank











Petrol tank



Hydraulic oil tank

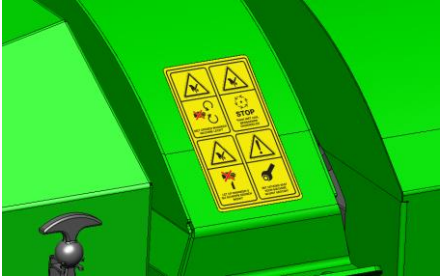

Hydraulic oil tank

	<p>Feed roller motor safety</p>	 <p>Feed roller motor</p>
	<p>Feed roller cover safety (Do not open)</p>	 <p>Top face of feed roller cover</p>
	<p>Feed control bar</p>	 <p>Feed control bar</p>
	<p>Rotor cover safety</p>	 <p>Rotor cover</p>
	<p>Recommended oil fill level</p>	 <p>Aligned with '80' to the left of the fuel gauge</p>

Hansa chipper industrial limited warranty

The warranty applies to new purchased HANSA product identified by the Chipper Serial number as part of this registration process. HANSA warrants each new HANSA Chipper free from defect in material and workmanship under normal use and routine servicing, for the warranty period specified below and conditional to the limitations and exclusions printed below.

Your Warranty Registration confirmation email is your identification for warranty service.

The purchaser must keep a record of all service and maintenance history as proof of servicing history. This may be requested when assessing any future warranty claim.

To qualify for this HANSA Limited Warranty the warranty registration must be completed within ten (10) days, following the date of purchase.

The warranty registration must accompany the HANSA product when warrantable repairs are requested. If the warranty registration is lost or destroyed, proof of purchase documentation clearly recognising the chipper serial number shall be accepted for warranty purposes. Where neither is available and HANSA does not have any record of the purchaser's details the warranty period shall be calculated from the appropriate dealer wholesale sale date. Any claim under this warranty must be made within the warranty period specified below.

Any authorised HANSA dealer is further authorised to repair or replace any part which proves defective within the limits of this warranty at no charge to the owner, covering parts and labour. Consumables items such as but not limited to oils, grease, knives and belts shall be the responsibility of the owner. All defective parts replaced under this warranty become the property of HANSA. Transportation cost for the product either to or from an authorised HANSA dealer is the responsibility of the owner.

This Hansa Chippers Limited Warranty may be subject to cancellation if the above requirements are not performed.

Your Warranty Registration confirmation email is your identification for warranty service. To take advantage of the HANSA limited warranty

- Use only an authorised HANSA dealer for servicing to ensure the safe operation of this product. The cost of routine or required maintenance and services is the responsibility of the purchaser.
- Maintenance has to be performed according to the maintenance section contained in the relevant owner's manual supplied with this product by an authorised HANSA dealer

In New Zealand Hansa Products Ltd will recognise your statutory rights under the Consumers Guarantee Act 1993.

In Australia this warranty is given by Hansa Australia Pty Ltd.

This warranty is provided in addition to other rights and remedies you have under law: Our goods come with guarantees which cannot be excluded under the Australian Consumer Law.

You are entitled to replacement or refund for a major failure and to compensation for other reasonably foreseeable loss or damage. You are entitled to have the goods repaired or replaced if the goods fail to be of acceptable quality and the failure does not amount to a major failure.

Exclusions

The warranties contained herein shall NOT APPLY TO:

- Any damage which results from neglect of periodic maintenance specified by HANSA.
- Any damage which results from repair or maintenance operations by methods other than specified by HANSA.
- Any damage which results from misuse or use beyond the limitations of the intended purpose specified by HANSA, such as overloading, including foreign objects such as stones, pieces of steel, glass etc being dropped into the running chipper or use under abnormal conditions (in HANSA's sole judgement).
- Any damage which results from use of non-genuine parts, lubricant or fluid not approved by HANSA.
- Any damage resulting from modification or installation in other products in a way not approved by Hansa which has any influence on the function and/or performance of the products.
- Any damage which results from operation other than specified in the Owner's Manual either intentionally or by error.
- Fading of painted surfaces, deterioration of plated surfaces, deterioration of rubber and plastics including, rusting due to the passage of time.

- Normal phenomena such as noise, vibration or oil seepage which are considered by HANSA as not affecting the quality, function or performance of the product.
- Any damage due to improper storage or transport.
- Consumable replacement items: Belts, cutting knives, anvil, serviceable bearings.
- Periodical maintenance items such as cleaning, inspection and adjustments.
- Any repair and/or adjustment performed by persons other than an authorised dealer, or damage resulting there from. As a rule warranty shall not be applied to the repair or adjustment performed by persons other than an authorised dealer.
- Any repair and/or adjustment to correct improper or poor quality work previously performed.
- Incidental expenses incurred in the warranty claim. For example: additional expenses such as those for towing, communications, hotel and meals, incurred due to breakdown of the product at a remote location. Any expense related to personal injury and/or property damage, (exclusive of the product itself). Compensation for loss of time, commercial losses or rental costs of a substitute product during the period of adjustment.
- Any damage which results from unavoidable natural disasters, fire, collision, theft, etc.
- Any normal wear or deterioration, such as that of sliding or rotating parts caused under normal operating conditions. For example: Normal wear pivot points, rod ends and bearings.
- Any damage resulting from exposure of the product to soot and smoke, medicines and chemical agents, sea water, sea breeze, salt or other environmental phenomena.

Limitations

- HANSA reserves the right to modify, alter and improve any product without incurring any obligation to replace any product previously sold with such modification.
- In no event shall HANSA's liability exceed the purchase price of the product.
- Equipment and accessories not of HANSA's manufacture (such as engine, battery and tyres) are warranted only to the extent of the original manufacturer's warranty and subject to their allowance to HANSA only if found to be defective by such manufacturer.
- HANSA reserves the right to supply remanufactured parts as it deems appropriate.

Chipper Warranty Period

HANSA CHIPPERS	DOMESTIC	HIRE
Non Registered	12 Months	3 Months
Registered	24 Months (Conditional)*	3 months

* Conditional Warranty:

This is a HANSA extended warranty period for products that are:

- Purchased from a New Zealand or Australian HANSA Dealer after 1/05/2014.
- Registered at the time of sale through the Hansa Chippers website: www.hansachippers.com/registration
- Serviced by a HANSA Dealer in accordance with the Hansa service schedule using genuine HANSA parts.
- Meeting all other warranty requirements.

Contact details

New Zealand:

Hansa Products Ltd
 57 Te Kowhai Rd East
 PO Box 10323
 Northgate, Hamilton 3200
 New Zealand

Australia:

Hansa Australia Pty Ltd
 1/6 Gravel Pit Rd
 PO Box 3178
 Darra, QLD 4076
 Australia

Honda engine limited warranty

The warranty applies to new purchased HONDA product identified by the Engine Serial number as part of this registration process. Your Warranty Registration confirmation email is your identification for warranty service.

In New Zealand this warranty is given by Power & Marine Limited. In Australia this warranty is given by Honda Australia Motorcycle and Power Equipment Pty Ltd.

Honda Power Equipment warrants each new HONDA Engine free from defect in material and workmanship under normal use and routine servicing, for the warranty period specified below and conditional to the limitations and exclusions printed below. This warranty applies only to new HONDA engines fitted to Hansa Chippers distributed in New Zealand & Australia.

The purchaser must keep a record of all service and maintenance history as proof of servicing history. This may be requested when assessing any future warranty claim. To qualify for this HONDA Limited Warranty the warranty registration must be completed within ten (10) days, following the date of purchase.

The warranty registration must accompany the HONDA product when warrantable repairs are requested. If the warranty registration is lost or destroyed, proof of purchase documentation clearly recognising the engine serial number shall be accepted for warranty purposes. Where neither is available and Honda Power Equipment does not have any record of the purchaser's details the warranty period shall be calculated from the appropriate dealer wholesale sale date.

Any authorized HONDA Power Product dealer is further authorized to repair or replace any part which proves defective within the limits of this warranty at no charge to the owner, covering parts and labour. Consumables items such as but not limited to oils, coolants, filter and spark plugs shall be the responsibility of the owner. All defective parts replaced under this warranty become the property of Honda Power Equipment. Transportation cost for the product either to or from an authorized HONDA dealer is the responsibility of the owner.

To take advantage of the HONDA limited warranty maintenance must be performed according to the schedule contained in the relevant owner's manual supplied with this product by an authorised HONDA dealer. HONDA will recognise your statutory rights under the Consumers Guarantee Act 1993. To ensure the safe operation of this product, we strongly recommend that you only use an authorised HONDA dealer for servicing. Only authorised HONDA Dealers have access to all of the special tools and training required to maintain your HONDA product in peak operating condition.

The HONDA engine may be removed from the Hansa chipper by the OEM retailer before delivery to an authorized HONDA Engine or Power Equipment dealer for repair. The removal is not covered by the limited warranty.

Exclusions

- Any damage which results from neglect of periodic maintenance specified by Honda.
- Any damage which results from repair or maintenance operations by methods other than specified by Honda.
- Any product which has participated in a competition racing or rally event.
- Any damage which results from misuse or use beyond the limitations of the intended purpose specified by Honda, such as overloading, or use under abnormal conditions.
- Any damage which results from use of non-genuine parts, lubricant or fluid not approved by Honda.
- Any damage resulting from modification or installation in other products in a way not approved by Honda which has any influence on the function and/or performance of the products.
- Any damage which results from operation other than specified in the Owner's Manual either intentionally or by error.
- Fading of painted surfaces, deterioration of plated surfaces, deterioration of rubber and plastics including, rusting due to the passage of time.
- Normal phenomena such as noise, vibration or oil seepage which are considered by Honda as not affecting the quality, function or performance of the product.
- Any damage due to improper storage or transport.
- Consumable replacement items: Spark plugs, contact points, shear pins, fuel strainers, oil filter elements, air cleaner elements, brake shoes or pads, clutch components, fuses, motor brushes, gaskets, tube or hoses, belts, cutting knives, light bulbs, serviceable bearing.
- Petroleum and others fluids: Oil, grease, battery electrolyte, and radiator coolant. Other items specified by Honda.
- Periodical maintenance items such as cleaning, inspection and adjustments.
- Any repair and/or adjustment performed by persons other than an authorised dealer, or damage resulting there from. As a rule warranty shall not be applied to the repair or adjustment performed by persons other than an authorised dealer.

- Any repair and/or adjustment to correct improper or poor quality work previously performed.
- Incidental expenses incurred in the warranty claim. For example: additional expenses such as those for towing, communications, hotel and meals, incurred due to breakdown of the product at a remote location. Any expense related to personal injury and/or property damage, (exclusive of the product itself). Compensation for loss of time, commercial losses or rental costs of a substitute product during the period of adjustment.
- Any damage which results from unavoidable natural disasters, fire, collision, theft, etc.
- Any normal wear or deterioration, such as that of sliding or rotating parts caused under normal operating conditions. For example: Normal wear to pistons, piston rings, cylinder bores, piston pins, valve seats, stems and bearings.
- Any damage resulting from exposure of the product to soot and smoke, medicines and chemical agents, sea water, sea breeze, salt or other environmental phenomena.

Limitations

- Engines fitted to Hansa chippers sold outside New Zealand or Australia shall be covered for the periods below as part of Honda's World Wide Warranty. Periods of warranty cover are the same as specified below. A copy of the HONDA International Warranty Agreement is available upon request to Honda Power Equipment.
Honda Power Equipment stocks parts only for those engine models that it imports and distributes. There may be a delay in obtaining parts for other engine models not distributed by Honda Power Equipment.

How to claim warranty

In the event you are faced with a manufacturing fault with your Honda product you can claim a repair or part replacement under warranty if the following conditions are fulfilled:

- The problem is related to production quality or specifications of the engine.
- The engine is within the warranty period outlined in schedule
- The issue does not fall within the warranty exclusions listed.

Procedures

- Take your Honda engine or Honda Power Product to an authorised Honda Dealer.
- Present the Warranty Registration or invoice document providing proof of the date of purchase with reference to the Hansa chipper serial number as appropriate.

NOTE: Honda General Purpose engines are distributed to provide power to chippers and equipment that are manufactured and sold by OEMs, other than Honda. In this case the Honda warranty only covers defects relating to the engine, not the entire chipper equipment nor the parts of the equipment that are attached to a Honda engine that are part of the application.

- **Domestic Use:** Personal, residential or household use only.
- **Commercial Use:** All uses other than domestic use, including use for income producing (including farming) or rental purposes.

Engine Warranty Period

GENERAL PURPOSE ENGINES	DOMESTIC	COMMERCIAL
GX Engines	36 Months 48 Months (Conditional)*	36 Months

* Conditional Warranty:

This is a Honda Dealer extended warranty period items that are:

- Purchased from a New Zealand or Australian Honda Dealer after 1/01/2013.
- Registered at the time of sale through the Hansa Chippers website: www.hansachippers.com/registration
- Serviced by a Honda Dealer in accordance with the Honda service schedule using Genuine Honda parts and oil (proof required).
- Meeting all other warranty requirements.

NOTE: These warranty conditions apply to New Zealand and Australia only.

Contact Details

New Zealand:

Power & Marine Limited
P.O. Box 53053
Auckland Airport
Auckland 2150

Australia:

Honda Australia Motorcycle and Power Equipment Pty Ltd
1954-1956 Sydney Rd
Campbellfield
Vic 3061

Commissioning checklist and registration



It is the retailers' responsibility to ensure that this chipper is correctly commissioned for use, and that the purchase is registered with Hansa Chippers so as to provide the owner with the full benefit of the warranty policy.

Product registration must be completed online:

www.hansachippers.com/registration

For registration, you will require the chipper serial number and customer details.

It is the retailers' responsibility to check the following:

Final Assembly	Check all bolts for tightness including knives
Operation	Instruct the owner/operator on operating procedures and techniques
Safety	Instruct owner/operator on safety procedures
Maintenance	Explain the maintenance requirements and the importance of following the maintenance schedule to the owner/operator
Manual	Emphasise the importance of reading and understanding the manual in full before initial operation of the chipper